



Model : \_\_\_\_\_

Item : \_\_\_\_\_

Name: \_\_\_\_\_

### Main Features

- Stainless steel body.
- Easy to clean and hygienic.
- Ergonomic design.
- Adjustable legs.
- Long life, easy to operate and maintenance.
- Thermostatic temperature control 50°-300°C
- Tubular burner placed under the tank.
- Pilot light and valve with thermocouple.
- 350°C Safety thermostat.
- Novasit 820 gas valve.
- Piezo-electric burner ignition.
- Hand –wheel boost system.
- Water filling pipe controlled from front panel.
- 310 quality 10 mm thick base sheet.

### Short Form Specification

### Construction

APPROVAL: \_\_\_\_\_

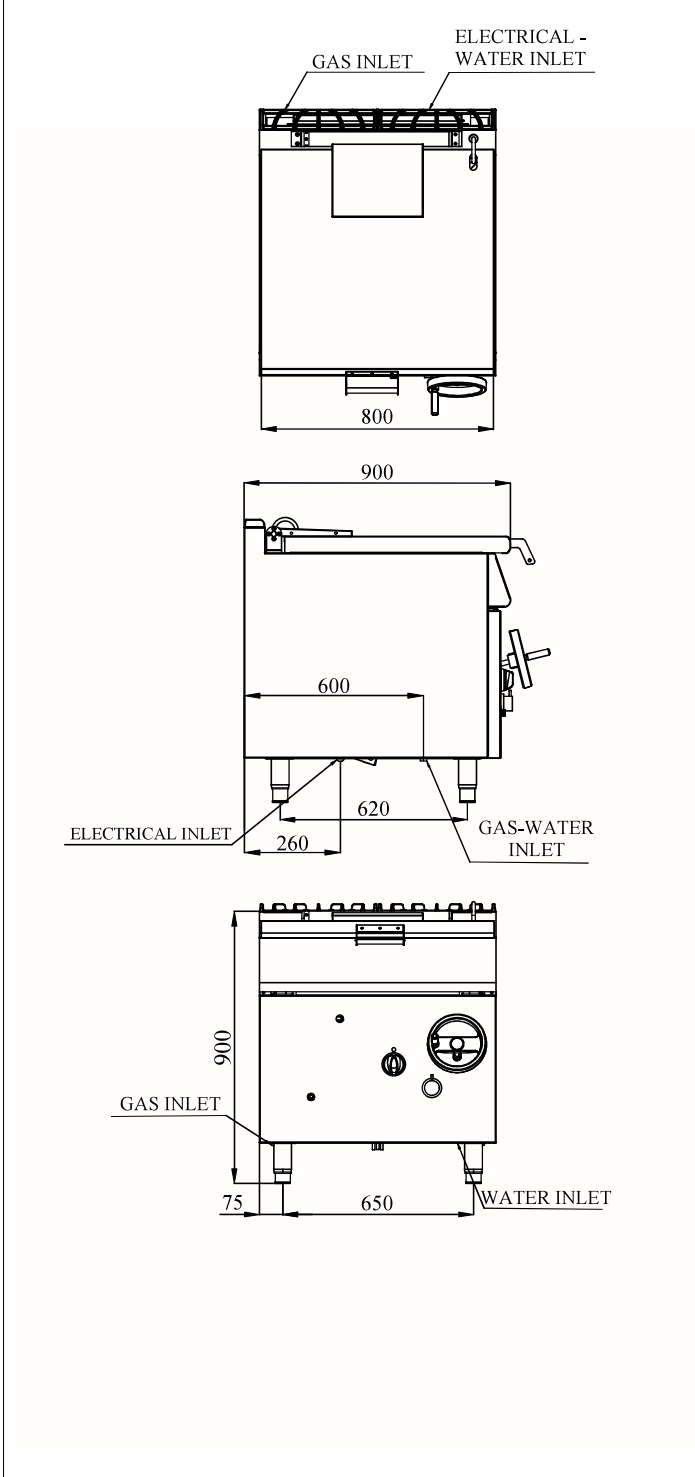

Code	7178.3120
Width (mm)	800 mm
Depth (mm)	900 mm
Hight (mm)	900 mm
Gross Weight (kg)	167
Gross Volume (m <sup>3</sup> )	1.08
Gas Inlet	1/2"
Water Inlet	1/2"
Power (kW)	20,5
Capacity (lt)	80